

ASM



ENABLING THE DIGITAL WORLD

SIPLACE TX

Maximum performance for the Integrated Smart Factory

SMART PERFORMANCE

SIPLACE TX THE PERFECT MACHINE FOR SMART FACTORIES



**Maximum performance
in a small footprint**

96,000 cph in a machine that
measures only 1 m x 2.23 m



Precise component feeding

80 x 8 mm tape feeders, JEDEC trays,
Glue Feeder, Linear Dipping Unit

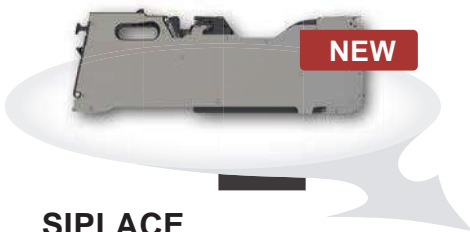

**SIPLACE
SmartFeeder Xi**

for best pickup performance
with high accuracy



3 placement heads



SIPLACE SpeedStar

48,000 cph –
the new benchmark
for components up to
8.2 mm x 8.2 mm

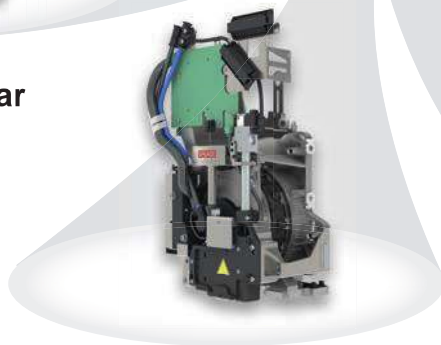

SIPLACE MultiStar

3 placement modes: Collect-and-
Place, Pick-and-Place, and Mixed Mode

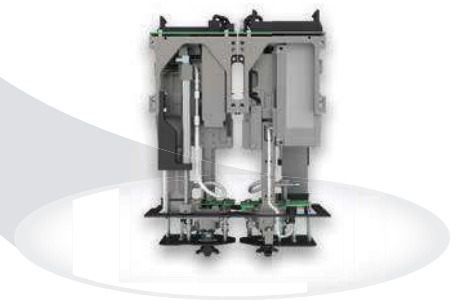

SIPLACE TwinStar

For components up to
200 mm x 125 mm



The smart factory needs smart machines: the SIPLACE TX is breaking all performance records with its new SIPLACE SpeedStar placement head and new SIPLACE SmartFeeder Xi.

MACHINE FOR THE RY

It boasts unique floor space performance, maximum throughput, perfect scalability in the line and smart software options.

The SIPLACE TX seamlessly fits into ASM's Smart Factory portfolio through heightened connectivity capabilities and functions as a state-of-the-art high performer for every type of electronics production.



SMART FEATURES

Wide component spectrum

Components ranging from

0.12 mm × 0.12 mm bis
200 mm × 125 mm are covered
with only three placement head types



Intelligent vision system

One image per component, component-specific lighting, PCB inspection, odd-shape placement, crack detection and much more.



Dual-lane transport

Two transport tracks allow maximum throughput. Long board options and board handling options offer flexibility.



Touchless/ low-force placement

Touchless placement and placement
forces as low as **0.5 N**



SMART CONNECTIVITY

Perfectly integrated into the smart factory

IIoT interfaces for integration into line and factory systems (ASM OIB, IPC-Hermes 9852, IPC-CFX) and the cloud (ADAMOS) with advanced workflow solutions for setup processes, material management, factory monitoring and factory integration, as well as remote support with ASM Remote Smart Factory.



SIPLACE TX



Machine type	SIPLACE TX2i (Item No. 588300)	SIPLACE TX2 (Item No. 588302)	SIPLACE TX1 (Item No. 588301)
Placement speed (benchmark rating)	Up to 96,000 cph	Up to 85,500 cph	Up to 44,000 cph
Machine dimensions (L x W x H)	1.00 m x 2.23 m x 1.45 m	1.00 m x 2.35 m x 1.45 m	
Placement heads	SIPLACE SpeedStar (CP20P2), SIPLACE MultiStar (CPP), SIPLACE TwinStar (TH)		
Component spectrum	0.12 mm x 0.12 mm to 200 mm x 125 mm**		
PCB dimensions (L x W)	50 mm x 45 mm to 550* x 260 mm (dual lane) 50 mm x 45 mm to 550* x 460 mm (single lane mode)		
Component feeding	up to 80 x 8 mm tape feeders, JEDEC trays, Linear Dipping Unit, Glue Feeder		
Typical power consumption	2.0 kW (with vacuum pump) 1.2 kW (without vacuum pump)		
Compressed air consumption	120 NI/min (with vacuum pump)		70 NI/min (with vacuum pump)

* With Long Board Option (without LBO, maximum PCB length 375 mm)

** With restrictions

Placement heads	SIPLACE SpeedStar (CP20P2)	SIPLACE MultiStar (CPP)	SIPLACE TwinStar (TH)
Component spectrum	0.12 mm x 0.12 mm to 8.2 mm x 8.2 mm	01005 to 50 mm x 40 mm	0201 to 200 mm x 125 mm
Component height	4 mm*	15.5 mm	25 mm
Placement accuracy (3 σ)	25 μ m	34 μ m	22 μ m
Maximum speed	48,000 cph	25,500 cph	5,500 cph
Placement force	0.5 N to 4.5 N	1.0 N to 15 N	1.0 N to 30 N

*2 mm on SIPLACE TX2i

Performing professional maintenance in the scope and intervals recommended by ASM ensures that your SIPLACE equipment will deliver the specified performance and accuracy across its entire life cycle. Our various maintenance contracts make this job even easier for you.

www.asm-smt.com

More about
SIPLACE TX



ASM Assembly Systems GmbH & Co. KG

Issue 12/12-2020 | All rights reserved | Order No.: A10011-ASM-G155-EN | Printed in Germany | © ASM Assembly Systems GmbH & Co. KG

The information in this brochure consists only of general descriptions and/or performance features which may not always apply to concrete products as described or which may change as a result of technical developments or advances. Any specific performance features and/or capabilities will only be binding if contractually agreed upon. All product names are brands or trademarks of ASM Assembly Systems GmbH & Co. KG or other suppliers. Their use by third parties may violate the rights of their owners.